

# 23 MVA In-house Emergency Power Generation Facilities for Kasai Water Reclamation Center

**Keywords** Kasai Water Reclamation Center, Dual-fuel gas turbine engine, Japan made gas turbine engine

## Abstract

Kasai Water Reclamation Center of Bureau of Sewerage, Tokyo Metropolitan Government operates with two units of in-house emergency power generation system driven by diesel engines. Because of deterioration of these facilities, however, these units were renewed by two units of 23 MVA (18.4 MW) in-house emergency power generation system, driven by gas turbine engines.

For large-capacity in-house emergency power generation systems over 10 MVA, gas turbine engines made by overseas suppliers have conventionally been adopted as the prime mover. This time, however, Japanese gas turbine engines (Kawasaki Heavy Industries, Ltd.) were adopted.

Since it was difficult to secure liquid fuel at the time of the Great East Japan Earthquake, the supplied dual-fuel gas turbine engines are versatile for use with both kerosene and city gas. Fuel redundancy has improved system reliability.

## 1 Preface

Kasai Water Reclamation Center is located at the mouth of the Arakawa River. The sewage treatment facility of this Water Reclamation Center covers a treatment area of 4889 hectares situated over most parts of Edogawa City, Tokyo and a part of Katsushika City. Since the in-house emergency power generation systems installed in the Center had been in service for more than 40 years, the Center decided to replace these units due to the deterioration (aging) of the facilities. This paper introduces the outlines of these 23 MVA (18.4 MW) in-house emergency power generation systems manufactured and supplied by Meiden, and some on-site delivery scenes of the system.

## 2 Outlines of Facilities

**Fig. 1** shows an external appearance of the 23 MVA in-house emergency power generation system and **Fig. 2** shows an outlined diagram of a single-line connection. The overall power generation system consists of two units of 23 MVA (18.4 MW) in-house emergency power generation system and a single unit of a 900 kW gas compressor. The generated power is supplied at 6.3 kV to the premises of the Center. We shipped to this site a large-capacity



**Fig. 1** 23 MVA In-house Emergency Power Generation System

The generator main body and its prime mover connected with the generator are shown.

Japan made dual-fuel gas turbine engine. Features of this engine are introduced below. **Table 1** shows specifications of major equipment.

### 2.1 Japan Made Gas Turbine Engine

Conventionally, overseas gas turbine engines were adopted whenever the capacity of any in-house emergency power generator exceeded 10 MVA. Nevertheless, this time we adopted Japan made gas

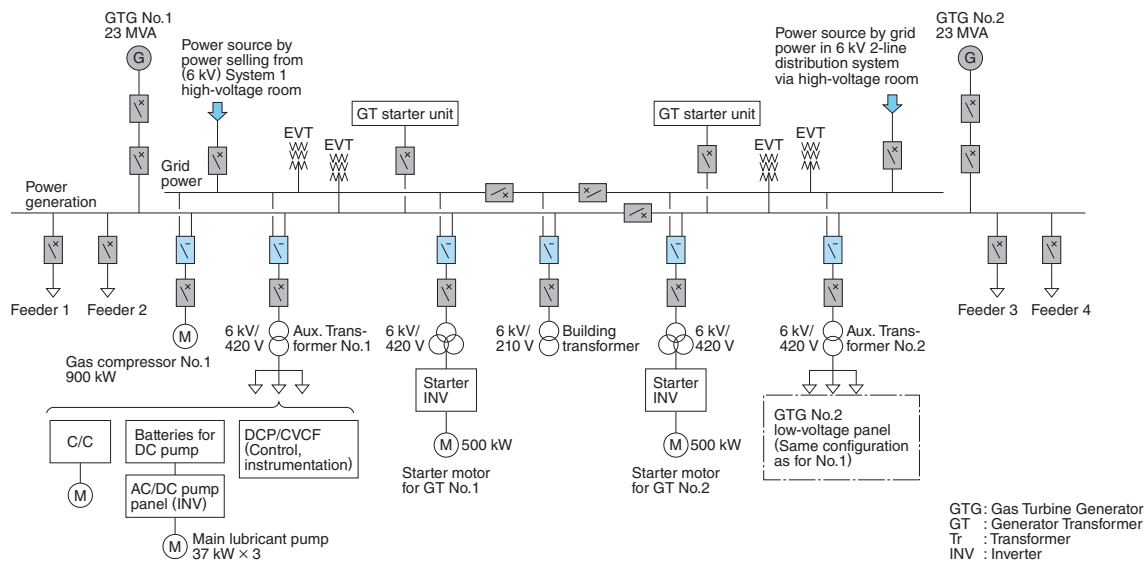

**Fig. 2 Outlined Diagram of Single-Line Connection**

This system is composed of two units of the 23 MVA in-house emergency power generation system and a single unit of 900 kW gas compressor.

**Table 1 Specifications of Major Equipment for In-house Emergency Power Generation Facilities**

Specifications of major equipment configuration are shown for the prime mover, generator, and gas compressor.

Equipment	Item	Specifications
Prime mover	Type	Simple open cycle biaxial type
	Rated output	Generator output 18,400 kW
	Annual running hours	Class A
	Annual starting frequency	Range II
	Starter unit	Electric start (Inverter motor)
	Starting time	Within 4 minutes (from start command to voltage establishment)
	Fuel used	Kerosene, city gas
Generator	Type	Horizontal-axis, air-cooled, totally-enclosed cylindrical rotating field type
	Ratings	Continuous
	Rated output	23,000 kVA
	Rated voltage	6.3 kV
	Rated frequency	50 Hz
	No. of phases	3-phase
	Power factor	80%
	Current	2108 A
	Rotating speed	3000 min <sup>-1</sup>
	Heat resistant class	155(F)
Gas compressor	Type	Oil-cooled type screw compressor
	Compression system	Single-stage compressor
	Discharge pressure	3.5 MPa
	Motor	900 kW

turbine engines (made by Kawasaki Heavy Industries, Ltd.). Since the equipment are made by Japanese manufacturers, prompt recovery actions can be taken even in the event of a mechanical malfunction.

## 2.2 Dual-Fuel Gas Turbine Engine

Soon after the Great East Japan Earthquake on 11 March 2011, there was unusual development, such that kerosene could not be secured due to the impacts of the earthquake disasters. In spite of this, the supply of city gas was continued due to the in-house emergency power generation system being capable of assuring a long time of operation and power supply. It did so by securing the fuel redundancy based on the dual use of liquid fuel and city gas that can be supplied stably.

## 3 Equipment Delivery

Since the supplied in-house emergency power generation systems (engines and generators) came in large sizes, these systems could not be transported in a completely assembled state. Consequently, each system was split into module level and then transported. After these units were carried into the project site, the module units were reassembled. The mass of an engine was about 33 tons, and a generator was approximately 44 tons respectively. For this reason, these units were carried into the project site by using a 220-ton all terrain crane. Fig. 3 shows a mounting frame when the engine was unloaded.

### 3.1 Ground Curing for Outdoor Equipment Carry-in Area

Since equipment and carry-in cranes to be delivered in were heavy, ground curing was carried out by using iron plates spread over the ground of the roads at the project site and in underground structures situated in the carry-in area.

### 3.2 Installation of Temporary Carry-in Racks

The carry-in entrance of the building is located at a higher level of the ground. Accordingly, temporary carry-in racks were installed for smooth carry-in work. Fig. 4 shows a mounting frame when the engine was brought in.



**Fig. 3** Mounting Frame when Engine was Unloaded

The crane used for equipment carry-in is also regarded as a special large-sized vehicle. For this reason, mechanical components were carried in late at night and the boom and mass were reassembled on the Center's premises.

.....

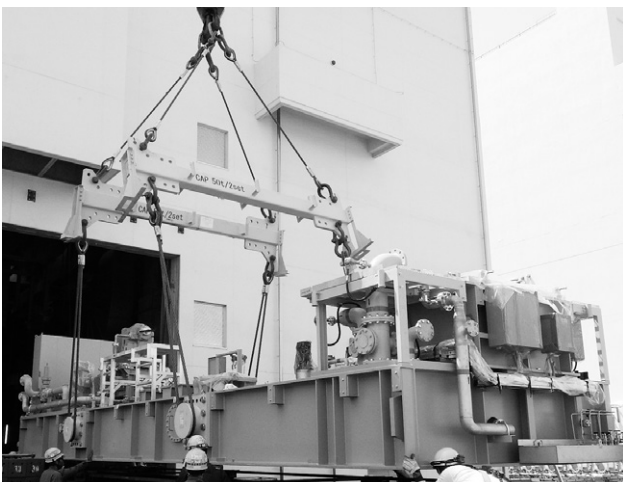

**Fig. 4** Mounting Frame when Engine was Brought in

Since there was a difference in height between outdoor ground level and the building entrance, a temporary mounting frame was employed.

### 3.3 Entry of Carry-in Vehicle (Special Vehicle)

Since the carry-in vehicle is a large and special vehicle, permission for a road passage was secured in advance and the vehicle was moved into the Center in the middle of the night.

### 3.4 Equipment On-Site Assembly

Since the equipment was too large and it was difficult to secure an ample space to reassemble the equipment components inside the room, reassembly work was carried out on an outdoor temporary mounting frame. Fig. 5 shows a view of engine reassembly work.

### 3.5 Indoor Carry-in and Installation

Fig. 6 shows the time of indoor carry-in. After the outdoor assembly work was completed, it was



**Fig. 5** Engine Reassembly Work

Engine reassembly work was carried out on a temporary mounting frame.

.....

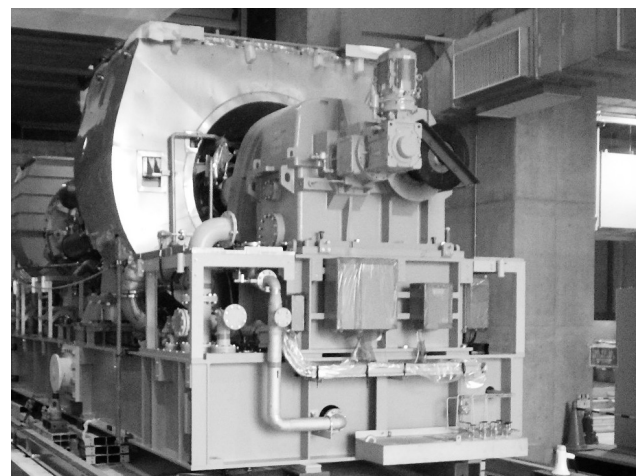

**Fig. 6** Time of Indoor Carry-in

A manual winch and rollers were used to manually pull the reassembled equipment horizontally and carry it into the room.

manually brought into the room, pulled horizontally using a manual winch and rollers.

## 4 Postscript

The in-house emergency power generation systems supplied this time are currently performing well. In the case of a utility power outage, the necessary power is supplied and stable sewerage treat-

ment is continued at Kasai Water Reclamation Center.

Lastly, we would like to express our profound gratitude to the people involved with this project for your kind guidance and cooperation during the phases of design, manufacture, and installation work for these facilities.

• All product and company names mentioned in this paper are the trademarks and/or service marks of their respective owners.